

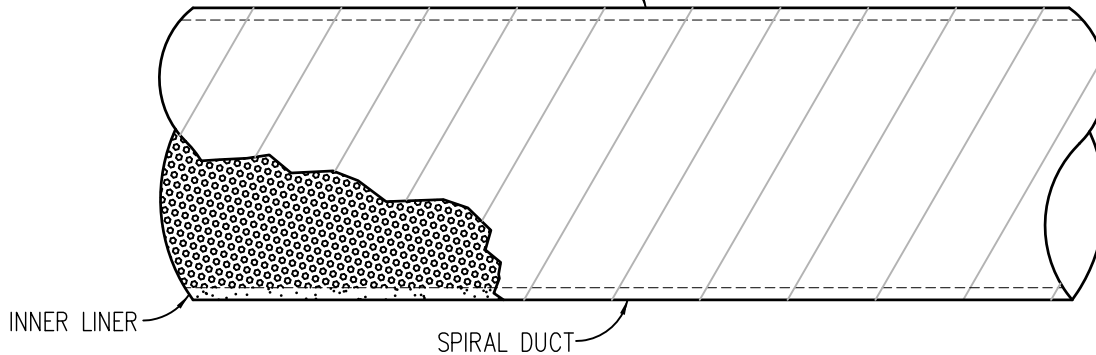

SPIRAL LOCK SEAM DUCT
FABRICATED WITH A SPIRO
TUBE FORMER MODEL 1600



GENERAL NOTES:

PERFORATED LINER TO BE 1/8" HOLES @ 3/16"

STAGGERED CENTERS 22 GAUGE

INSULATION TO BE CERTAINTeed 1 1/2 LB/CU. FT. 1" THICK

DOUBLE WALL SPIRAL DUCT PLAN VIEW

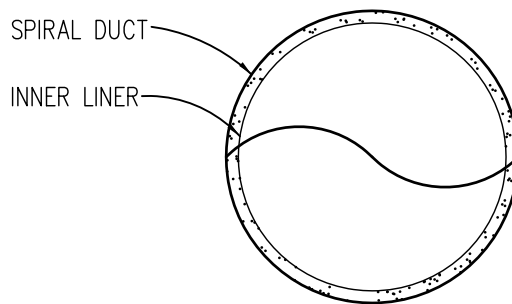

DOUBLE WALL SPIRAL DUCT END VIEW

SPIRAL DUCT
4" PRESSURE CLASSIFICATION

DIMENSION DUCT DIAMETER	MINIMUM GAUGE	JOINTS AND CONNECTION
0"-26"	24	SLIP OR FLANGE
27"-36"	22	SLIP OR FLANGE
37"-50"	20	SLIP OR FLANGE
51"-60"	18	COMPANION FLANGE
61" & UP	18	COMPANION FLANGE

SUBJECT TO CHANGE WITHOUT NOTICE



9135 KING STREET • ANCHORAGE, ALASKA 99515-1927
PHONE: 907-522-5959 • FAX: 907-522-6006

PROJECT:

ENGINEER:

CONTRACTOR:

TITLE:

ACOUSTICAL DUCTWORK SUBMITTAL



GENERAL NOTES:

PERFORATED LINER TO BE 1/8" HOLES @ 3/16"
STAGGERED CENTERS 22 GAUGE
INSULATION TO BE CERTAINTeed 1 1/2 LB/CU. FT. 1" THICK

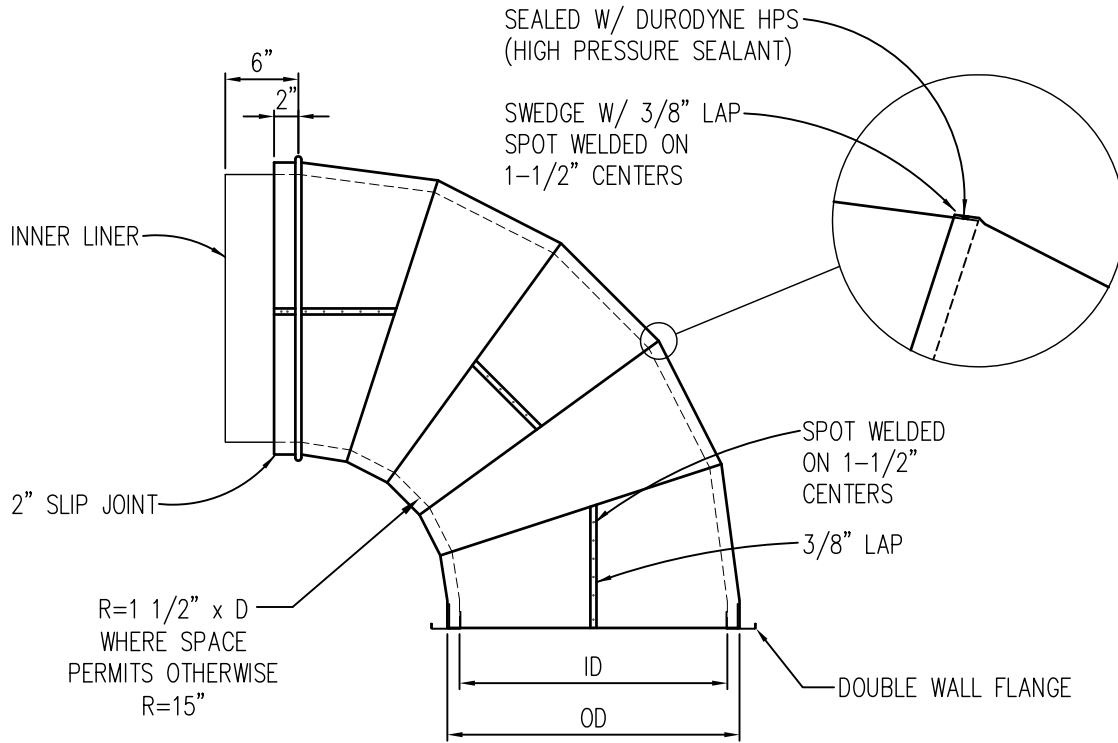

DOUBLE-WALL ROUND ELL 0° - 90°

1" OR 2" LINER

DIMENSION DUCT DIAMETER	DEGREE ELBOW	NUMBER OF GORES	JOINTS AND CONNECTION
0"-14"	45° & 90° (ONLY)	DIE FORMED	SLIP

DEGREE ELBOW	NUMBER OF GORES	DIMENSION DUCT DIAMETER	MINIMUM GAUGE	JOINTS AND CONNECTION
0-45°	3	0"-26"	22	SLIP OR FLANGE
46-60°	4	27"-36"	20	SLIP OR FLANGE
61-90*	5	37"-50"	20	SLIP OR FLANGE
		51" & 60"	18	COMPANION FLANGE
		61" & UP	16	COMPANION FLANGE

NOTE:
SEALING REQUIREMENTS COMPLY WITH SMACNA CLASS A, 4" W.G. AND UP ALL TRANSVERSE JOINTS, LONGITUDINAL SEAMS W/ DURODYNE HPS (HIGH PRESSURE SEALANT)

* FABRICATED AS TWO PIECES

SUBJECT TO CHANGE WITHOUT NOTICE



9135 KING STREET • ANCHORAGE, ALASKA 99515-1927
PHONE: 907-522-5959 • FAX: 907-522-6006

PROJECT:	
ENGINEER:	
CONTRACTOR:	
TITLE:	ACOUSTICAL DUCTWORK SUBMITTAL

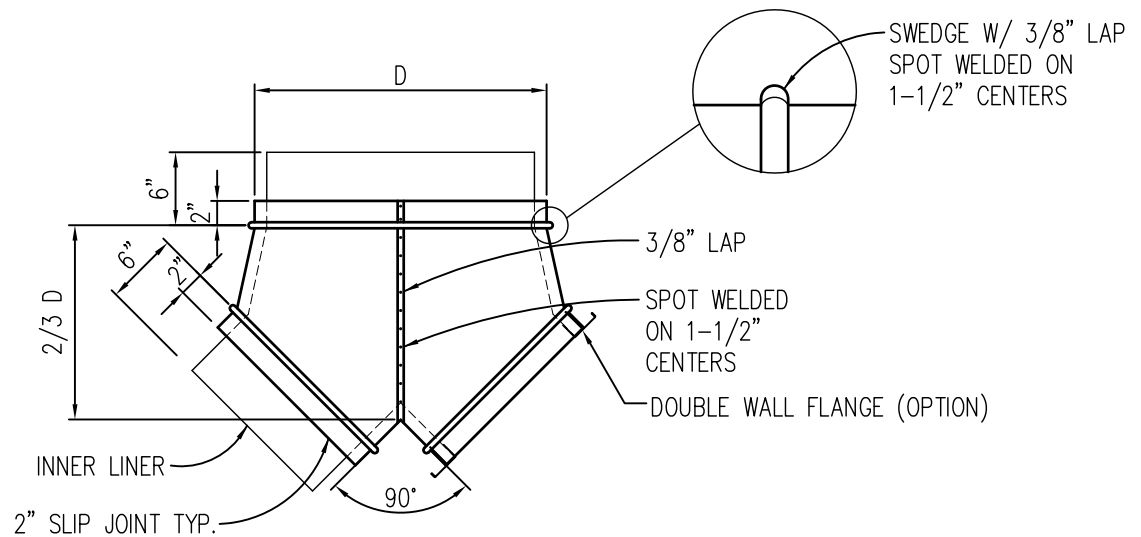

DOUBLE WALL WYE FITTING

1" OR 2" LINER

DIMENSION DUCT DIAMETER	MINIMUM GAUGE	JOINTS AND CONNECTION
0"-26"	22	SLIP OR FLANGE
27"-36"	20	SLIP OR FLANGE
37"-50"	20	SLIP OR FLANGE
51" & 60"	18	COMPANION FLANGE
61" & UP	16	COMPANION FLANGE

NOTE:
SEALING REQUIREMENTS COMPLY WITH
SMACNA CLASS A, 4" W.G. AND UP
ALL TRANSVERSE JOINTS, LONGITUDINAL
SEAMS W/ DURODYNE HPS
(HIGH PRESSURE SEALANT)

GENERAL NOTES:

PERFORATED LINER TO BE 1/8" HOLES @ 3/16"
STAGGERED CENTERS 22 GAUGE
INSULATION TO BE CERTAINTIED 1 1/2 LB/CU. FT. 1" THICK

SUBJECT TO CHANGE WITHOUT NOTICE



9135 KING STREET • ANCHORAGE, ALASKA 99515-1927
PHONE: 907-522-5959 • FAX: 907-522-6006

PROJECT:	
ENGINEER:	
CONTRACTOR:	
TITLE:	ACOUSTICAL DUCTWORK SUBMITTAL

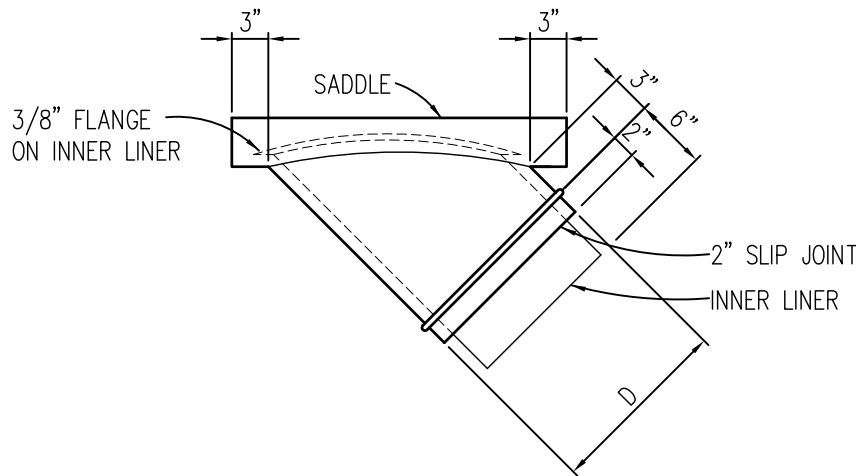

DOUBLE WALL 45° TAP WITH SADDLE

DIMENSION DUCT DIAMETER	MINIMUM GAUGE	JOINTS AND CONNECTION
0"-26"	22	SLIP OR FLANGE
27"-36"	20	SLIP OR FLANGE
37"-50"	20	SLIP OR FLANGE
51" & 60"	18	COMPANION FLANGE
61" & UP	16	COMPANION FLANGE

NOTE:
SEALING REQUIREMENTS COMPLY WITH
SMACNA CLASS A, 4" W.G. AND UP
ALL TRANSVERSE JOINTS, LONGITUDINAL
SEAMS W/ DURODYNE HPS
(HIGH PRESSURE SEALANT)

GENERAL NOTES:

PERFORATED LINER TO BE 1/8" HOLES @ 3/16"
STAGGERED CENTERS 22 GAUGE
INSULATION TO BE CERTAINTIED 1 1/2 LB/CU. FT. 1" THICK

SUBJECT TO CHANGE WITHOUT NOTICE



9135 KING STREET • ANCHORAGE, ALASKA 99515-1927
PHONE: 907-522-5959 • FAX: 907-522-6006

PROJECT:

ENGINEER:

CONTRACTOR:

TITLE:

ACOUSTICAL DUCTWORK SUBMITTAL

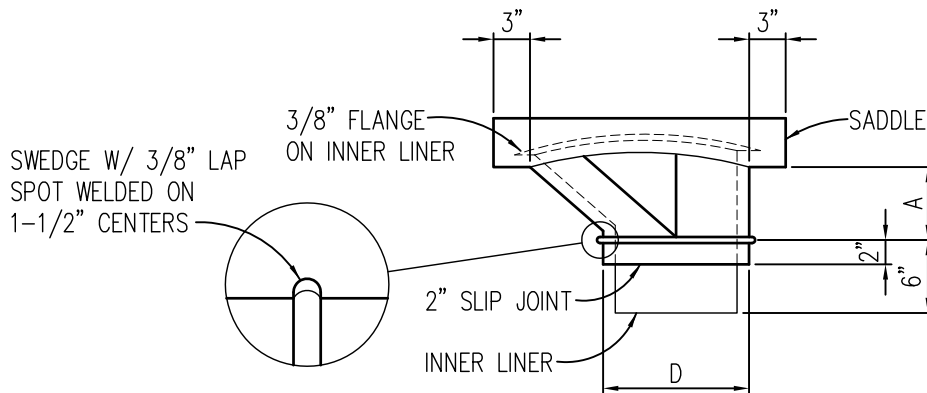

A= 3" WHEN D=3"-8"
 6" WHEN D=9"-16"
 9" WHEN D=17"-24"
 12" WHEN D=25" & UP

DOUBLE WALL 90° OVAL TO ROUND TAP WITH SADDLE

DIMENSION DUCT DIAMETER	MINIMUM GAUGE	JOINTS AND CONNECTION
0"-26"	22	SLIP OR FLANGE
27"-36"	20	SLIP OR FLANGE
37"-50"	20	SLIP OR FLANGE
51" & 60"	18	COMPANION FLANGE
61" & UP	16	COMPANION FLANGE

NOTE:
 SEALING REQUIREMENTS COMPLY WITH
 SMACNA CLASS A, 4" W.G. AND UP
 ALL TRANSVERSE JOINTS, LONGITUDINAL
 SEAMS W/ DURODYNE HPS
 (HIGH PRESSURE SEALANT)

GENERAL NOTES:

PERFORATED LINER TO BE 1/8" HOLES @ 3/16"
 STAGGERED CENTERS 22 GAUGE
 INSULATION TO BE CERTAINTIED 1 1/2 LB/CU. FT. 1" THICK

SUBJECT TO CHANGE WITHOUT NOTICE



9135 KING STREET • ANCHORAGE, ALASKA 99515-1927
 PHONE: 907-522-5959 • FAX: 907-522-6006

PROJECT:	
ENGINEER:	
CONTRACTOR:	
TITLE:	ACOUSTICAL DUCTWORK SUBMITTAL

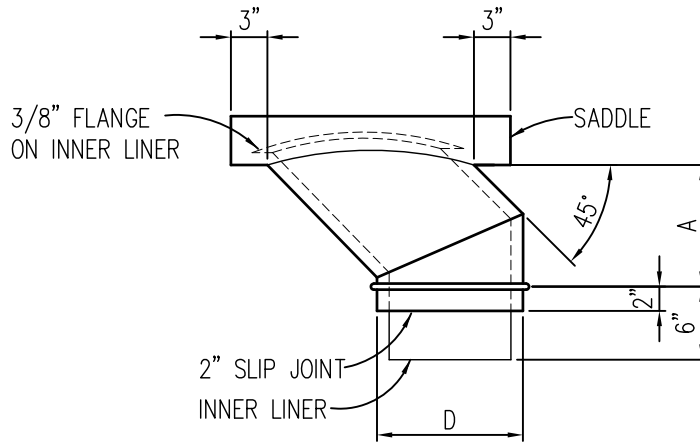

A= 5"	WHEN D= 4"ø
5"	5"ø
5 1/2"	6"ø
6"	7"ø
6 1/2"	8"ø
7"	9"ø
8 1/2"	10"ø
10"	12"ø
11"	14"ø
12"	16"ø
13"	18"ø
14"	20"ø
15"	22"ø
16"	24"ø
17"	26"ø

DOUBLE WALL 45/90 TAP WITH SADDLE

DIMENSION DUCT DIAMETER	MINIMUM GAUGE	JOINTS AND CONNECTION
0"-26"	22	SLIP OR FLANGE
27"-36"	20	SLIP OR FLANGE
37"-50"	20	SLIP OR FLANGE
51" & 60"	18	COMPANION FLANGE
61" & UP	16	COMPANION FLANGE

NOTE:
SEALING REQUIREMENTS COMPLY WITH
SMACNA CLASS A, 4" W.G. AND UP
ALL TRANSVERSE JOINTS, LONGITUDINAL
SEAMS W/ DURODYNE HPS
(HIGH PRESSURE SEALANT)

GENERAL NOTES:

PERFORATED LINER TO BE 1/8" HOLES @ 3/16"
STAGGERED CENTERS 22 GAUGE
INSULATION TO BE CERTAINTIED 1 1/2 LB/CU. FT. 1" THICK

SUBJECT TO CHANGE WITHOUT NOTICE



9135 KING STREET • ANCHORAGE, ALASKA 99515-1927
PHONE: 907-522-5959 • FAX: 907-522-6006

PROJECT:

ENGINEER:

CONTRACTOR:

TITLE:

ACOUSTICAL DUCTWORK SUBMITTAL

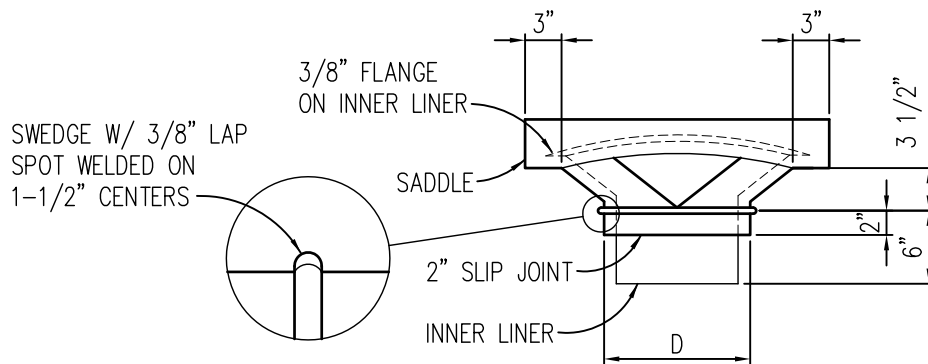

DOUBLE WALL 90° CONICAL TAP WITH SADDLE

DIMENSION DUCT DIAMETER	MINIMUM GAUGE	JOINTS AND CONNECTION
0"–26"	22	SLIP OR FLANGE
27"–36"	20	SLIP OR FLANGE
37"–50"	20	SLIP OR FLANGE
51" & 60"	18	COMPANION FLANGE
61" & UP	16	COMPANION FLANGE

NOTE:

SEALING REQUIREMENTS COMPLY WITH SMACNA CLASS A, 4" W.G. AND UP ALL TRANSVERSE JOINTS, LONGITUDINAL SEAMS W/ DURODYNE HPS (HIGH PRESSURE SEALANT)

GENERAL NOTES:

PERFORATED LINER TO BE 1/8" HOLES @ 3/16"

STAGGERED CENTERS 22 GAUGE

INSULATION TO BE CERTAINTIED 1 1/2 LB/CU. FT. 1" THICK

SUBJECT TO CHANGE WITHOUT NOTICE



9135 KING STREET • ANCHORAGE, ALASKA 99515-1927
PHONE: 907-522-5959 • FAX: 907-522-6006

PROJECT:

ENGINEER:

CONTRACTOR:

TITLE:

ACOUSTICAL DUCTWORK SUBMITTAL

GENERAL NOTES:

- PERFORATED LINER TO BE 1/8" HOLES @ 3/16"
- STAGGERED CENTERS 22 GAUGE
- INSULATION TO BE CERTAINTeed 1 1/2 LB/CU. FT. 1" THICK

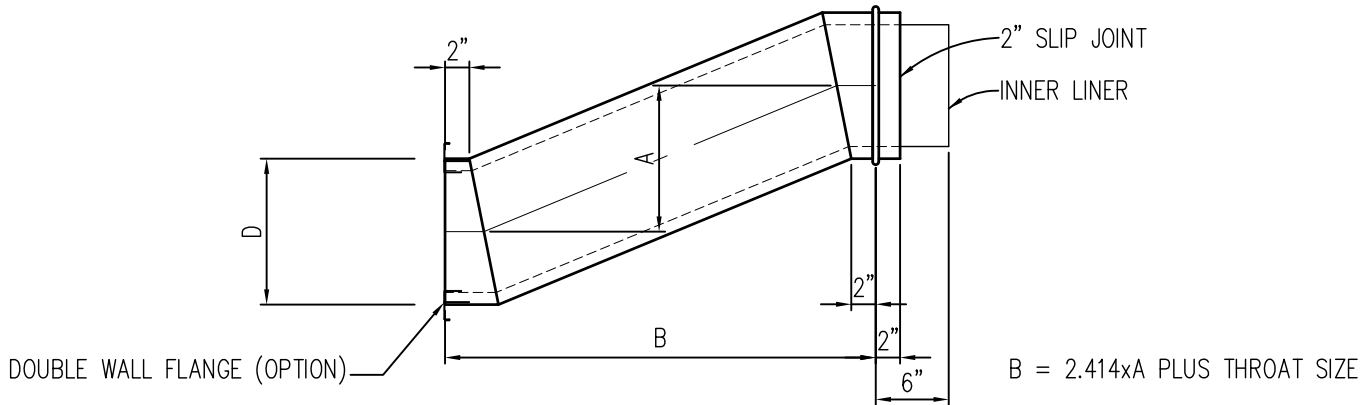

DOUBLE WALL 22 1/2° OFFSET

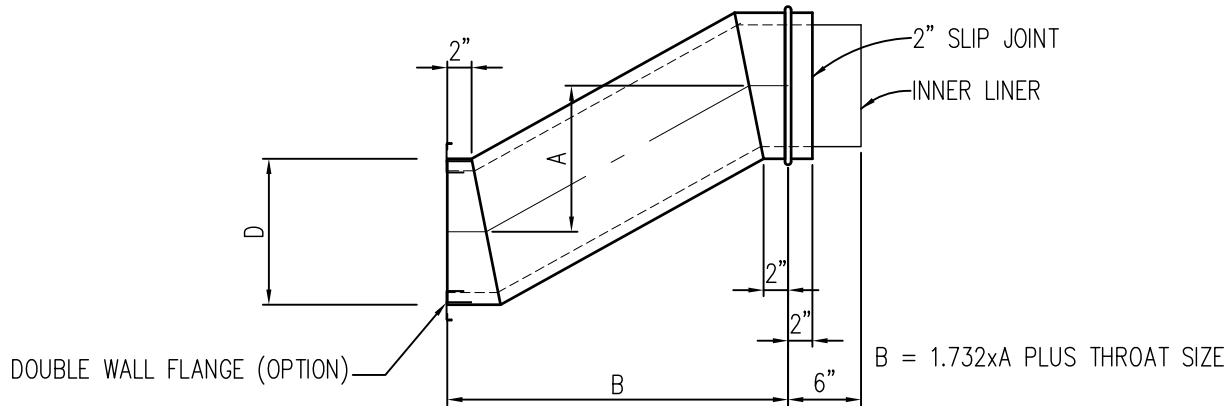

DOUBLE WALL 30° OFFSET

DIMENSION DUCT DIAMETER	MINIMUM GAUGE	JOINTS AND CONNECTION
0"–26"	22	SLIP OR FLANGE
27"–36"	20	SLIP OR FLANGE
37"–50"	20	SLIP OR FLANGE
51" & 60"	18	COMPANION FLANGE
61" & UP	16	COMPANION FLANGE

NOTE:
SEALING REQUIREMENTS COMPLY WITH SMACNA CLASS A, 4" W.G. AND UP ALL TRANSVERSE JOINTS, LONGITUDINAL SEAMS W/ DURODYNE HPS (HIGH PRESSURE SEALANT)

SUBJECT TO CHANGE WITHOUT NOTICE



9135 KING STREET • ANCHORAGE, ALASKA 99515-1927
PHONE: 907-522-5959 • FAX: 907-522-6006

PROJECT:	
ENGINEER:	
CONTRACTOR:	
TITLE:	ACOUSTICAL DUCTWORK SUBMITTAL

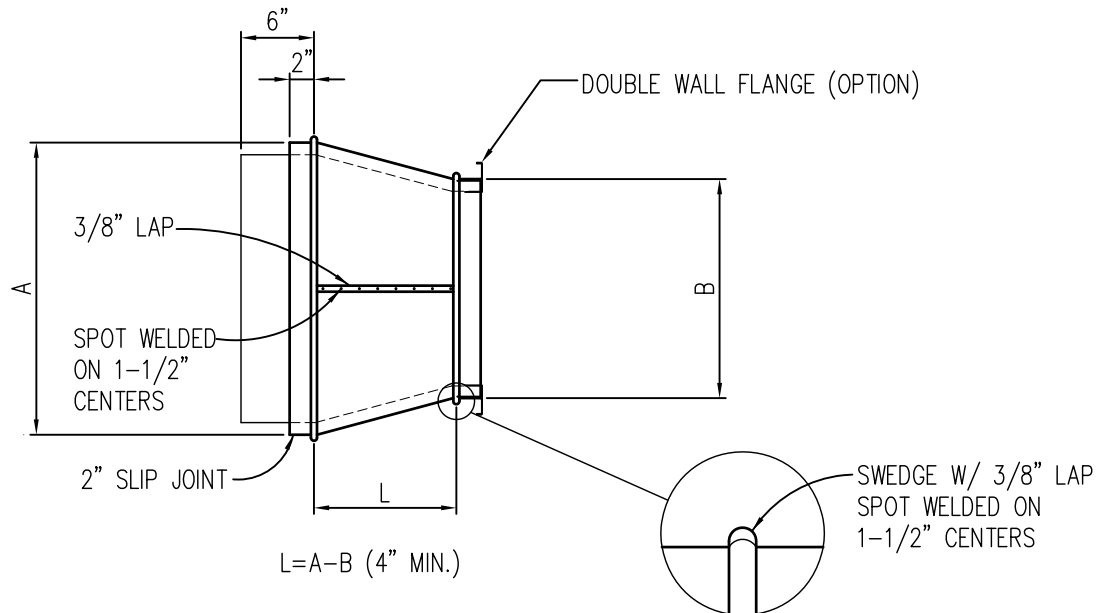

DOUBLE WALL REDUCER 1" OR 2" LINER

DIMENSION DUCT DIAMETER	MINIMUM GAUGE	JOINTS AND CONNECTION
0"-26"	22	SLIP OR FLANGE
27"-36"	20	SLIP OR FLANGE
37"-50"	20	SLIP OR FLANGE
51" & 60"	18	COMPANION FLANGE
61" & UP	16	COMPANION FLANGE

NOTE:
SEALING REQUIREMENTS COMPLY WITH
SMACNA CLASS A, 4" W.G. AND UP
ALL TRANSVERSE JOINTS, LONGITUDINAL
SEAMS W/ DURODYNE HPS
(HIGH PRESSURE SEALANT)

GENERAL NOTES:

PERFORATED LINER TO BE 1/8" HOLES @ 3/16"
STAGGERED CENTERS 22 GAUGE
INSULATION TO BE CERTAINTeed 1 1/2 LB/CU. FT. 1" THICK

SUBJECT TO CHANGE WITHOUT NOTICE



9135 KING STREET • ANCHORAGE, ALASKA 99515-1927
PHONE: 907-522-5959 • FAX: 907-522-6006

PROJECT:	
ENGINEER:	
CONTRACTOR:	
TITLE:	ACOUSTICAL DUCTWORK SUBMITTAL

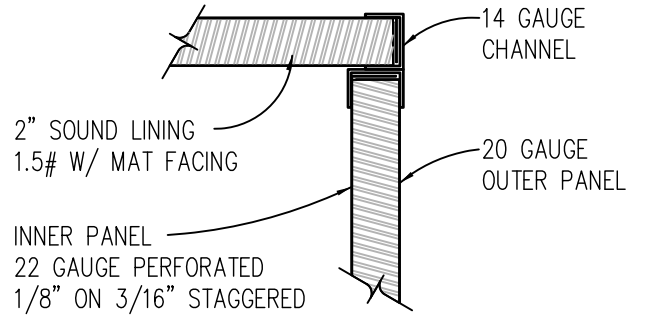
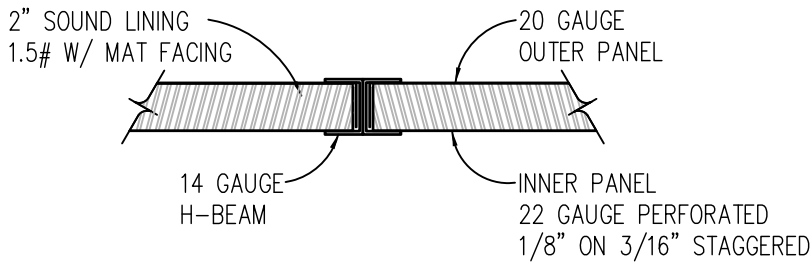

TYPICAL PANNEL CONECTION

TYPICAL CORNER

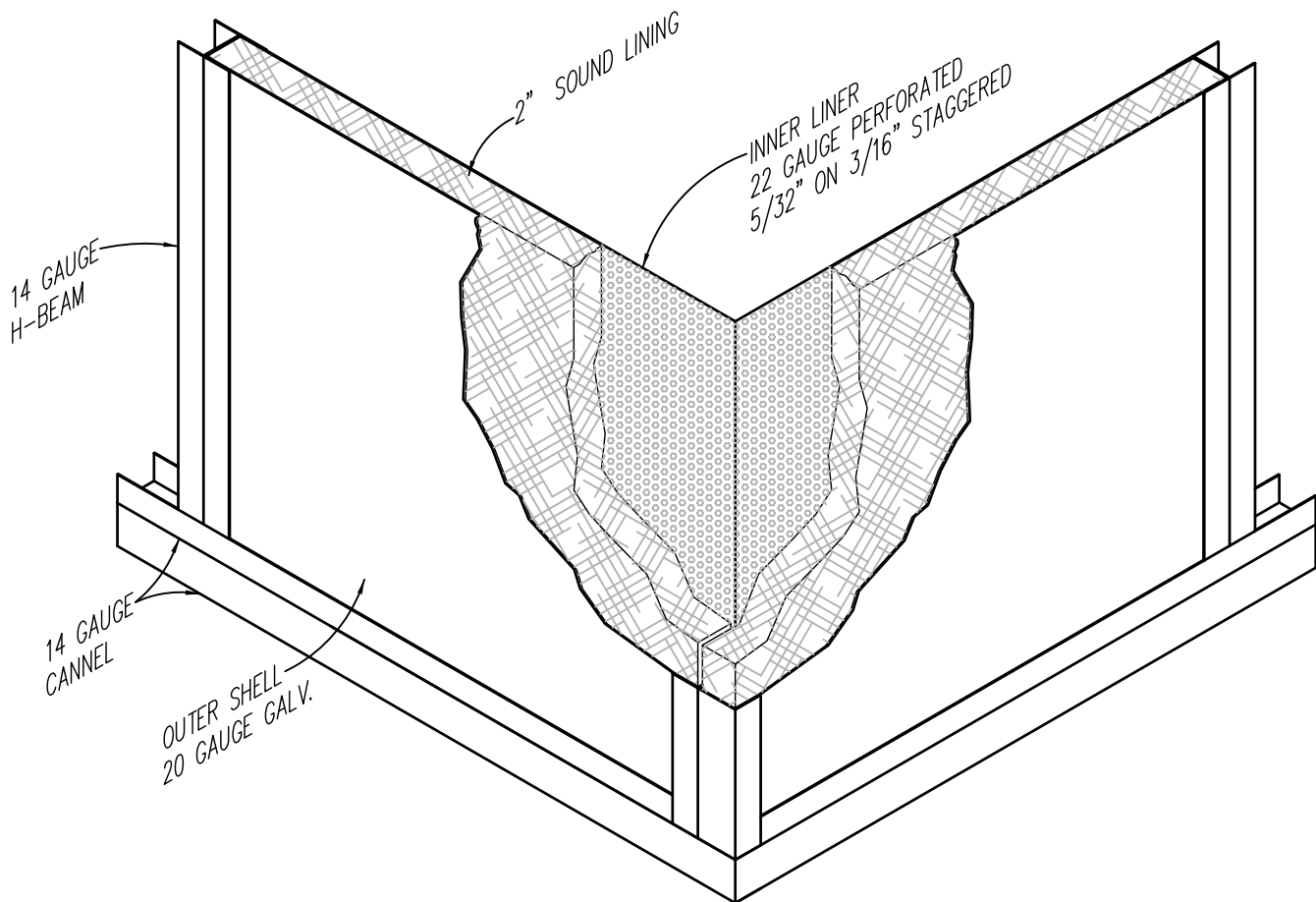

DOUBLE WALL PLENUM PANEL

SUBJECT TO CHANGE WITHOUT NOTICE



9135 KING STREET • ANCHORAGE, ALASKA 99515-1927
PHONE: 907-522-5959 • FAX: 907-522-6006

PROJECT:

ENGINEER:

CONTRACTOR:

TITLE:

ACOUSTICAL DUCTWORK SUBMITTAL